

MICROBLUE®



3 YEAR WARRANTY

PERFORMANCE

17dba

| MAX FLOW | MAX HEAD | MAX LIFT |
|-----------|----------|----------|
| 5 L/ HOUR | 5 METRES | 2 METRES |

The MicroBlue® uses a revolutionary dynamic diaphragm control technology, allowing it to outperform other condensate pumps. The compact, anti-vibration design makes it suitable for conduit installations or similar discrete locations.

SENSING OPTION

MICROBLUE® pump available with:

| RESERVOIR | FACIA KIT | DUCTING KIT |
|--|-----------|------------------------------------|
| X86-001 (HLA-PACK) X86-002 (FSA-PACK) | T18-016 | X86-005 (IVORY) X86-006 (WHITE) |
| | | |



DYNAMIC OPERATION

Thanks to intelligent sensing technology the pump can dynamically adjust to condensate levels to operate in the quietest and most efficient possible way.



PUMP INTELLIGENCE

Reservoir and pump interconnectivity allows onboard intelligence to provide installers with accurate system analysis via a light display on the pump.



EASY INSTALL

Modular power supply design allows express installation, by simplifying the fiddly cable routing process.

DISCHARGE PIPE RUN

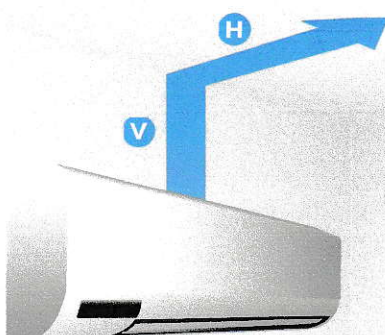

*3.5 KW MAX



UNIT

3.5 KW

PERFORMANCE

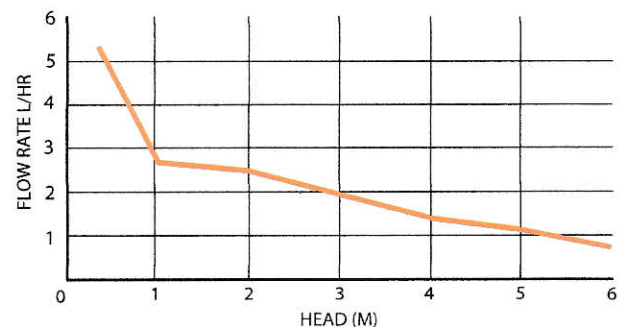

DIMENSIONS (MM)

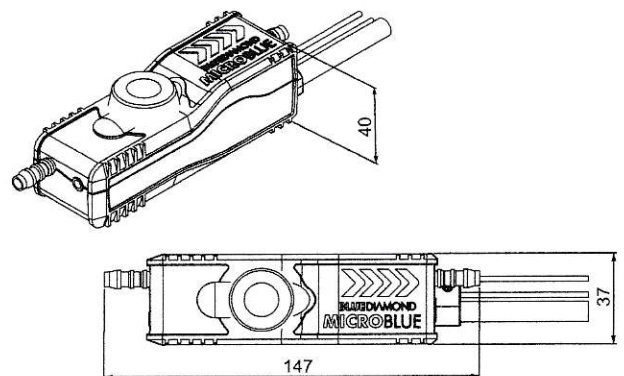

| V (VERTICAL) | H (HORIZONTAL) |
|--------------|----------------|
| 5 M | 0 M |
| 4 M | 3 M |
| 3 M | 6 M |
| 2 M | 9 M |
| 1 M | 12 M |

The MICROBLUE® can be mounted in any orientation up to 2m away from the air conditioning unit.